



McDonnell & Miller

Installation & Maintenance
Instructions
MM-221(F)

Model 157S-RBP-MD
(Snap Switch)



Low Water Cut-Off/Pump Controller

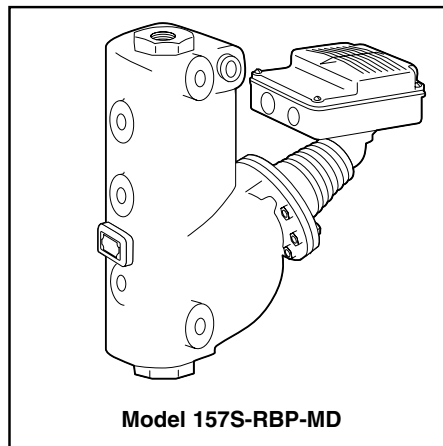

Applications:

For bi-level pump control applications such as multiple boiler level operation.

WARNING

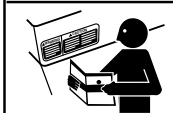

- Before using this product read and understand instructions.

- Save these instructions for future reference



- All work must be performed by qualified personnel trained in the proper application, installation, and maintenance of plumbing, steam, and electrical equipment and/or systems in accordance with all applicable codes and ordinances.

- To prevent serious burns, the boiler must be cooled to 80°F (27°C) and the pressure must be 0 psi (0 bar) before servicing.



- To prevent electrical shock, turn off the electrical power before making electrical connections.

- This low water cut-off must be installed in series with all other limit and operating controls installed on the boiler. After installation, check for proper operation of all of the limit and operating controls before leaving the site.

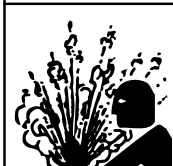

- We recommend that secondary (redundant) Low Water Cut-Off controls be installed on all steam boilers with heat input greater than 400,000 BTU/hour or operating above 15 psi of steam pressure. At least two controls should be connected in series with the burner control circuit to provide safety redundancy protection should the boiler experience a low water condition. Moreover, at each annual outage, the low water cut-offs should be dismantled, inspected, cleaned, and checked for proper calibration and performance.



- To prevent serious personal injury from steam blow down, connect a drain pipe to the control opening to avoid exposure to steam discharge.

- To prevent a fire, do not use this low water cut-off to switch currents over 7.4A, 1/3 Hp at 120 VAC or 3.7A, 1/3 Hp at 240 VAC, unless a starter or relay is used in conjunction with it.

Failure to follow this warning could cause property damage, personal injury or death.

OPERATION

Maximum Pressure: 150 psi (10.5 kg/cm²)

Electrical Ratings

Float Control

Voltage	Pump or Motorized Valve Circuit Rating (Amperes)		Pilot Duty
	Full Load	Locked Rotor	
120 VAC	7.4	44.4	345 VA at 120 or 240 VAC
240 VAC	3.7	22.2	

Alarm Circuit Rating	
Voltage	Amps
120 VAC	1
240 VAC	1/2

Motor Horsepower	
Voltage	Amps
120 VAC	1/3
240 VAC	1/3

Probe Control (750BM-P-120-CI)

Voltage	Pump or Motorized Valve Circuit Rating (Amperes)	
	Full Load	Locked Rotor
120 VAC	7.2	43.2
240 VAC	3.75	21.6

Probe Sensitivity:

- 26,000 ohms

Probe Input Power

- 120 volts

Settings and Differential Pressures:

* Values are $\pm 1/8$ " (3.2mm).

157S-RBP-MD

Pressure	Setting	Approximate Distance Above Cast Line In. (mm)	Differential In. (mm)
Probes Any Pressure	Pump Off	5 ¹ / ₂ (140)	1 ¹ / ₂ (38)
	Pump On	4 (102)	
Float 0 psi (0 kg/cm ²)	Pump Off	15/16 (24)	3/8 (16)
	Pump On	9/16 (14)	
	Burner Off	0	N/A
Float 150 psi (10.5 kg/cm ²)	Pump Off	17/16 (37)	3/4 (19)
	Pump On	11/16 (17)	
	Burner Off	-3/8 (-16)	N/A

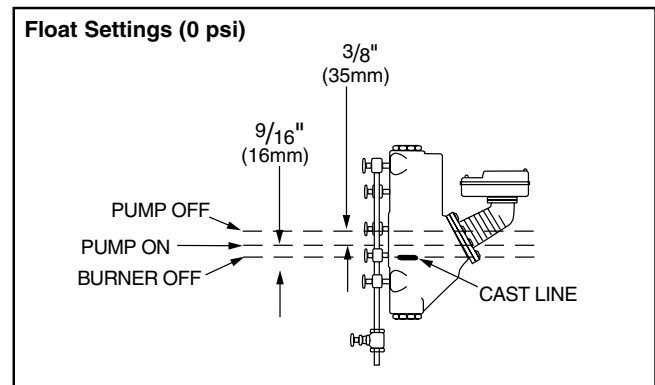
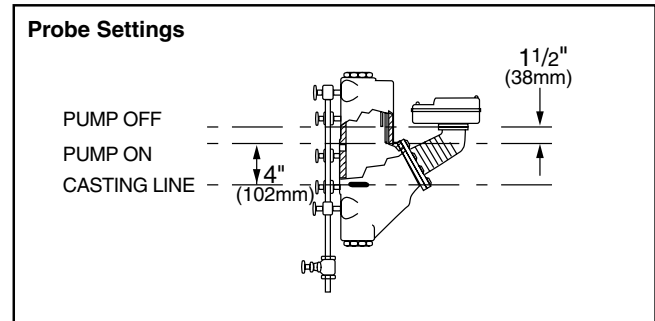

INSTALLATION –

TOOLS NEEDED:

Two (2) pipe wrenches, one (1) flathead screw driver, and pipe sealing compound.

IMPORTANT: Follow the boiler manufacturer's instructions along with all applicable codes and ordinances for piping, blow down valve and water gauge glass requirements.

STEP 1 - Determine the Elevation at Which the Low Water Cut-Off/Pump Controller Must be Installed

Size the steam (top) and water (bottom) horizontal equalizing pipe lengths so that the horizontal cast line on the body is $1\frac{1}{2}$ " (38mm) **below** the boiler's **normal** water level, **but not lower than the minimum safe water level, as determined by the boiler manufacturer.**

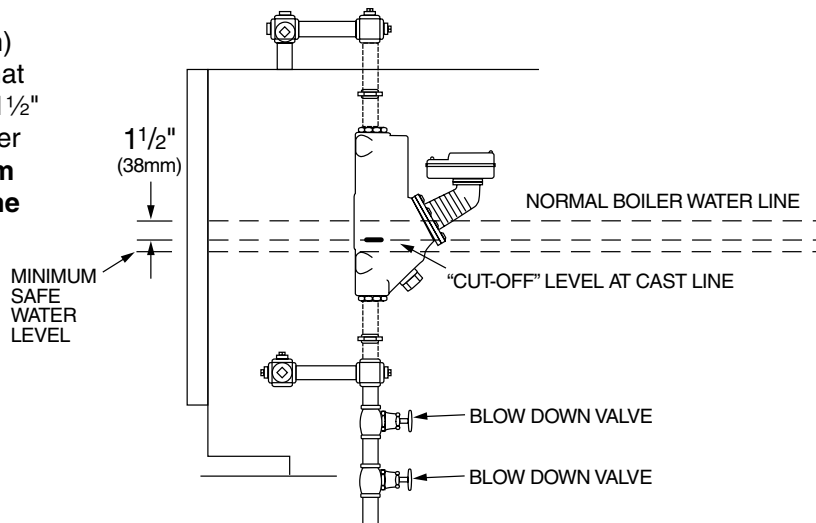

STEP 2 - Installing the Low Water Cut-Off

- a. Using a pipe wrench, unscrew the plastic float blocking plug (A) from the float block tapping of the low water cut-off body (B).

Install pipe plug (provided) to seal port.

CAUTION

The plug must be reinstalled before control is shipped installed on the boiler, and removed when boiler is installed after shipment.

Failure to follow this caution may damage float and operating mechanism

- b. Mount and pipe the low water cut-off (C) on a vertical equalizing pipe (D) at the required elevation level, as determined in Step 1.

Install full ported blow down valves directly below the lower cross of the water equalizing pipe (F).

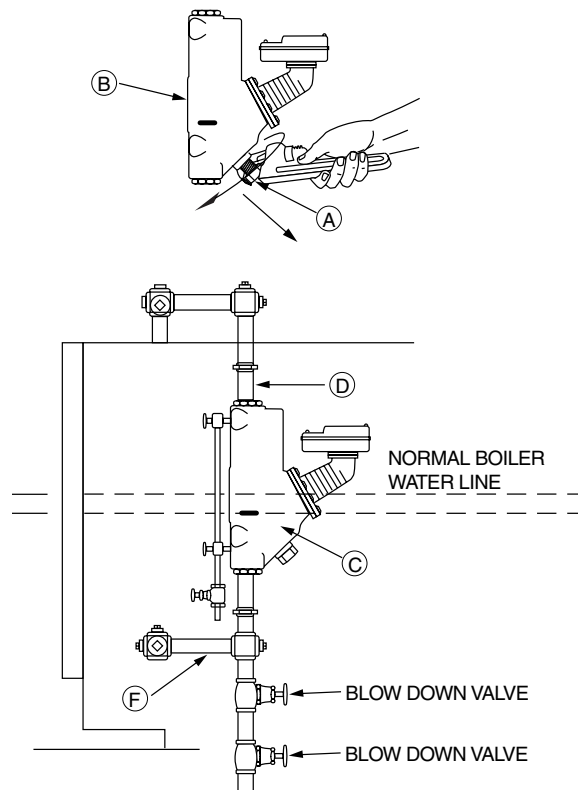

STEP 3 - Electrical Wiring

WARNING



- To prevent electrical shock, turn off the electrical power before making electrical connections.
 - This low water cut-off must be installed in series with all other limit and operating controls installed on the boiler. After installation, check for proper operation of all of the limit and operating controls, before leaving the site.
 - Modification of the switch assembly before or after installation could cause damage to the boiler and/or boiler system.
 - Boiler manufacturer schematics should always be followed. In the event that the boiler manufacturer's schematic does not exist, or is not available from the boiler manufacturer, refer to the schematics provided in this document.
- Failure to follow this warning could cause electrical shock, an explosion and/or a fire, which could result in property damage, personal injury or death.

Switch Operation - Float Control

Boiler feed pump off,
burner on, alarm off.

Boiler feed pump on,
burner on, alarm off.

Boiler feed pump on,
burner off, alarm on.

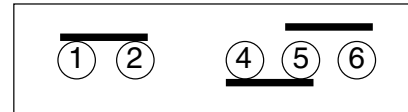
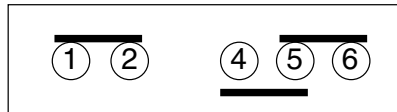

Switch Operation - Probe Control

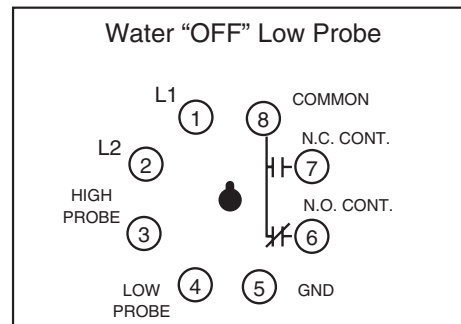
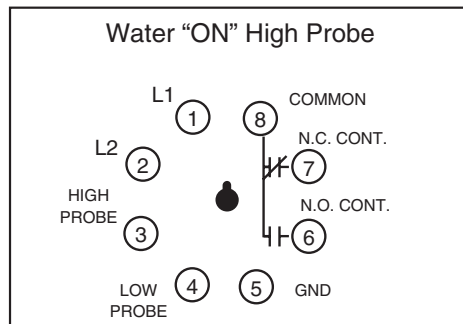

- Using a flathead screwdriver, remove the junction box cover (K) by unscrewing the four (4) cover screws.

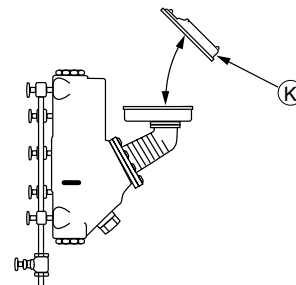

- b. Following the appropriate wiring diagram, (refer to page 6) based on your application requirements, and using BX armored cable or Thinwall electrical metal tubing connector fittings, make electrical connections to the junction box (L).

IMPORTANT: There must be a minimum space of 1/2" (13mm) between connector fittings and electrical live metal parts.

Snap Switches (Series 150S)

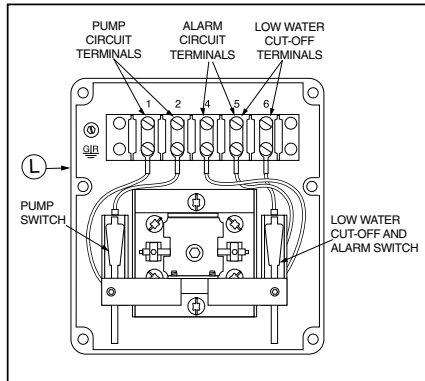

Installation of 750BM-P-120-CI

- Mount 750BM module using 8 pin socket base (supplied by others) in **Boiler Electrical Panel**.

NOTE

Boiler sight glass must be visible from location of Control Box and must be within 25 feet of Control Body.

- Install electrical conduit between **Probe Housing** and **Boiler Electrical Panel**.

NOTE

Wire must be 18 AWG stranded with glass braided silicone jacket (UL 3071) suitable for high temperature (200°C) service.

NOTE

Refer to and follow local codes and standards when selecting conduit and electrical fittings. Probe wires must be in their own conduit. If they are run in conduit with other wires, there may be interference that can affect the performance of the control.

- Pull three (3) wires through conduit.

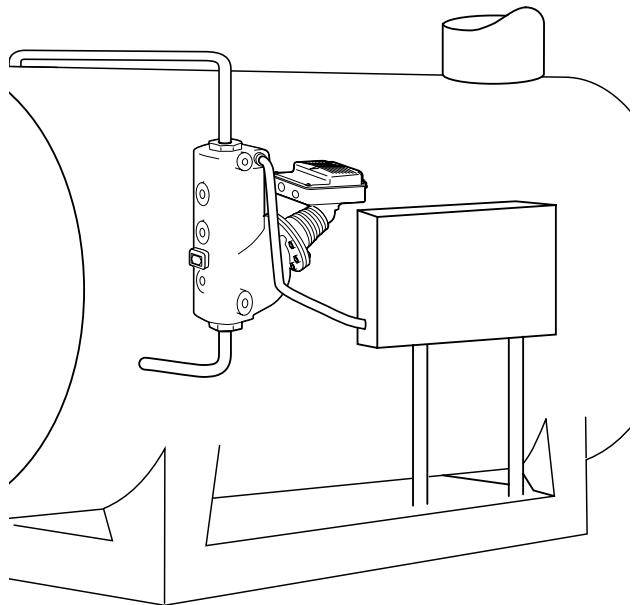

WIRING DIAGRAMS

Low Water Cut-Off Only

1. Main Line Switch - For burner circuits within the switch's electrical rating.

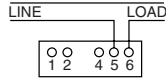

2. Pilot Switch - To holding coil of a starter when the burner circuit exceeds the switch's electrical rating.

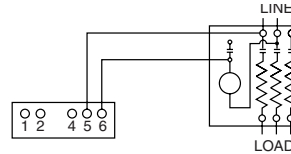

OR

Pump Control Only

1. Instal a starter or relay in pump control circuit, as shown, to prevent damage to snap switch and help insure proper switch/control operation. Failure to do so may shorten the life of the switch when actual amperage exceeds switch rating.

NOTE: To help insure most effective operation, balance boiler feed pump(s) to deliver required water feeder rate to match boiler steaming requirements.

2. Connect wires from holding coil of pump starter or relay to terminals 1 and 2 as shown.

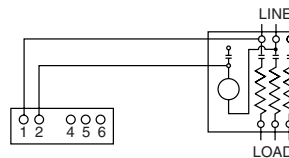

Alarm Circuit Only

1. Low Water Alarm

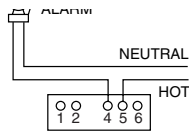

2. High Water Alarm

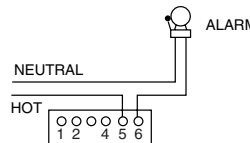

OR

Combination Pump Control, Low Water Cut-Off and Alarm

1. Main Line Switch - For burner circuits within the switch's electrical rating.

2. Pilot Switch-To holding coil of a starter when the burner circuit exceeds the switch's electrical rating.

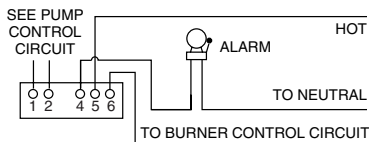

OR

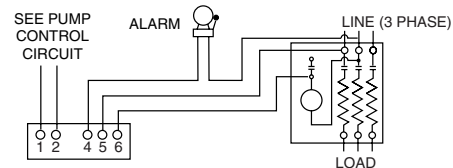

ELECTRONIC PROBES:

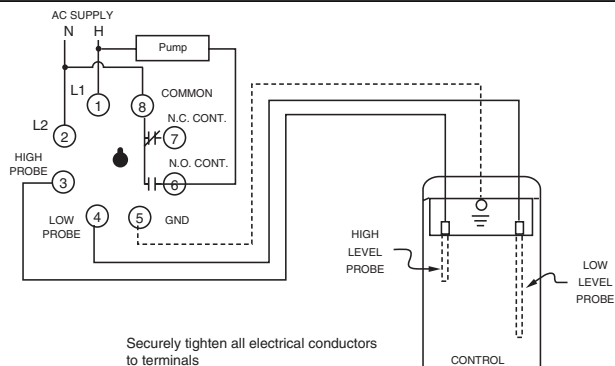



STEP 4 - Testing

This control is factory calibrated for specific level settings as shown on page 2 in the "Operation" section. The following testing procedure is only meant to serve as a verification of proper operating sequence.

IMPORTANT: Follow the boiler manufacturer's start-up and operating instructions along with all applicable codes and ordinances.

Standby Range Operation:

- a. Turn on the electric power to the boiler. The pump should go on and the burner must remain off.

 WARNING	
	If the burner comes on, immediately turn the boiler off and make the necessary corrections.
	Failure to follow this warning could cause an explosion or fire and result in property damage, personal injury or death.

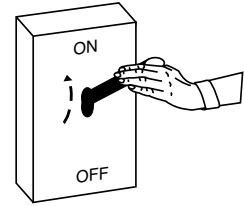

- b. The boiler should begin to fill with water. As the water level rises in the sight glass, the burner should turn on and then the pump should turn off. If the burner does not turn on or pump turn off at appropriate levels, immediately turn off the boiler and make the necessary corrections.

 CAUTION	
	To prevent serious personal injury from steam pipe blow down, connect a drain pipe to the control opening to avoid exposure to steam discharge.
	Failure to follow this caution could cause personal injury.

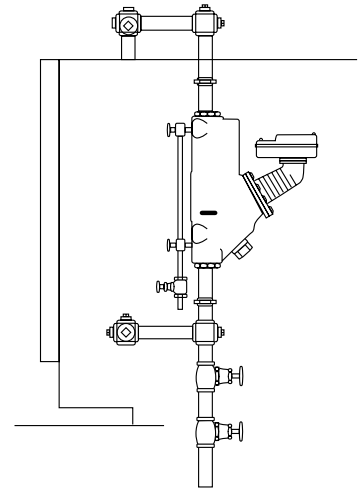

- c. Blow down the control when the water in the boiler is at its normal level and the burner is on. **Slowly** open the upper then the lower blow-down valves and observe the water level fall in the sight glass. Close the valves (lower first then upper) after verifying that the pump contacts have closed and the burner shuts off. If this does not happen, immediately shut off the boiler, correct the problem and retest.

INSTALLATION COMPLETE

MAINTENANCE

SCHEDULE:

Blow down control as follows when boiler is in operation.

- Daily if operating pressure is above 15 psi.
- Weekly if operating pressure is below 15 psi.

NOTE

More frequent blow-down may be necessary due to dirty boiler water and/or local codes.

- **Remove head assembly and inspect water side components annually.** Replace head assembly if any of the internal components are worn, corroded or damaged or if control no longer operates properly.
- **Inspect the float chamber and equalizing piping annually.** Remove all sediment and debris.

NOTE

The control may need to be inspected and cleaned more frequently on systems where there is the potential of excessive scale or sludge build-up. This includes systems:

- With high raw water make-up
- With no condensate return
- With untreated boiler water
- Where significant changes have been made to the boiler-water chemical treatment process
- With oil in the boiler water

Replace head mechanism every 5 years.

More frequent replacement may be required when severe conditions exist.

Replacement parts are available from your local authorized McDonnell & Miller Distributor.

The use of parts or components other than those manufactured by McDonnell & Miller will void all warranties and may affect the units compliance with listings or regulating agencies.



BLOW DOWN PROCEDURE:

CAUTION



To prevent serious personal injury from steam pipe blow down, connect a drain pipe to the control opening to avoid exposure to steam discharge.

Failure to follow this caution could cause personal injury.

When blowing down a control at pressure, the blow down valves should be opened slowly. The piping needs to be warmed up and stagnant water in the drain piping needs to be pushed out. Suddenly opening a blow down valve causes steam to condense, which can create water hammer. Damage to components can occur when water hammer occurs due to improper blow down piping. For these reasons, McDonnell & Miller recommends a dual valve blow-down system for each control.

Blow down the control when the water in the boiler is at its normal level and the burner is on.

NOTE: Refer to page 2 for switch operating points.

- Open upper valve (#1)
- Slowly open the lower valve (#2)
- Water in the sight glass should lower.
- As the water in the sight glass lowers, the pump should turn on.
- As the water continues to lower in the sight glass, the burner should turn off.
- Slowly close the lower valve (#2).
- Close the upper valve (#1)
- The water level in the sight glass should rise, first turning on the burner and then turning off the pump.

NOTE: On manual reset models, the reset button will need to be pressed after the water level has been restored before the burner will operate.

NOTE

If this sequence of operation does not occur as described, immediately close all the valves, turn off the boiler and correct the problem. Inspection/cleaning of the float mechanism may be required to determine why the control was not working properly. Retest the control after the problem has been identified and corrected.

