

# Replacement Pump and Burner Switch Arm Contacts with Terminal Panel



**SA91-30B**  
**SA91-30P**

**For installation on 5, 5-M, 7B or 7B-M  
 Switch Assemblies**

### Electrical Ratings

**Models with 5 or 5-M Switch**

Voltage	Pump and Burner Switch Contact Ratings Pilot Duty Only
120 VAC	345 VA
240 VAC	

**Models with 7B or 7B-M Switch**

Switch Ratings		
Burner	Valve	
120 VAC	345 VA	0 - 135 ohms @ 24 VAC
240 VAC		

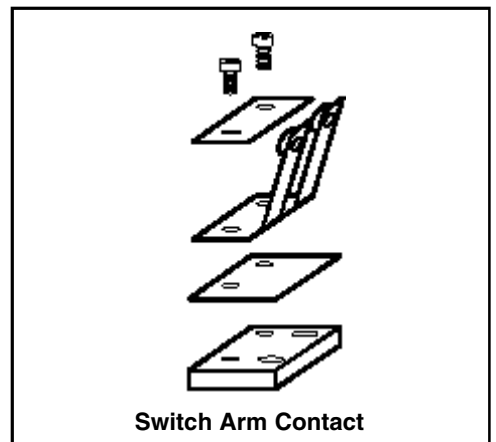
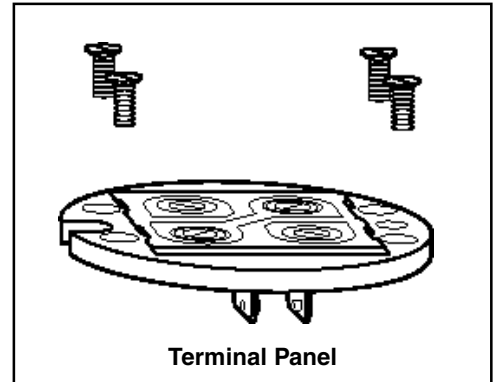

## ⚠ WARNING



- Before using this product read and understand instructions.
- Save these instructions for future reference.
- All work must be performed by qualified personnel trained in the proper application, installation, and maintenance of plumbing, steam, and electrical equipment and/or systems in accordance with all applicable codes and ordinances.
- To prevent a fire, do not exceed the switch contact rating.

Failure to follow this warning could cause property damage, personal injury or death.

*Engineered for life*

## STEP 1 - Removal and Replacement of Contacts and Terminal Panels

- a. Turn power off to boiler and all controls. Allow boiler to cool to 80°F (27°C) and reduce the pressure to 0 psi (0 bar).



### CAUTION

There may be more than one source of power to the boiler.

### b. Remove Switch Assembly, Terminal Panels and Switch Housing

- Remove two screws (A) and lift off **switch cover**.
- Identify **terminal connections** for rewiring and then disconnect all wires from **terminal panels**.
- Remove **conduit connector** and wire from integral **fitting hub**.
- Remove four hex nuts (B) and carefully lift **switch assembly** up and off **tower tube**.
- Remove two screws (C) and remove **nameplate**.
- Loosen and remove four screws (E) that hold **pump** and **burner terminal panels** in place. **Do not remove terminal panels at this time.**
- Reach through nameplate opening and hold **burner switch lever** about midway between upper and lower **stops** to move contact arms into correct (upright) position. With contact arms in upright position, carefully remove **burner terminal panel**.
- Reach through nameplate opening and hold **pump switch lever** about midway between upper and lower **stops** to move contact arms into correct (upright) position. With contact arms in upright position, carefully remove **pump terminal panel**.
- Loosen four screws (E) and carefully lift **switch housing** up off **base plate**.

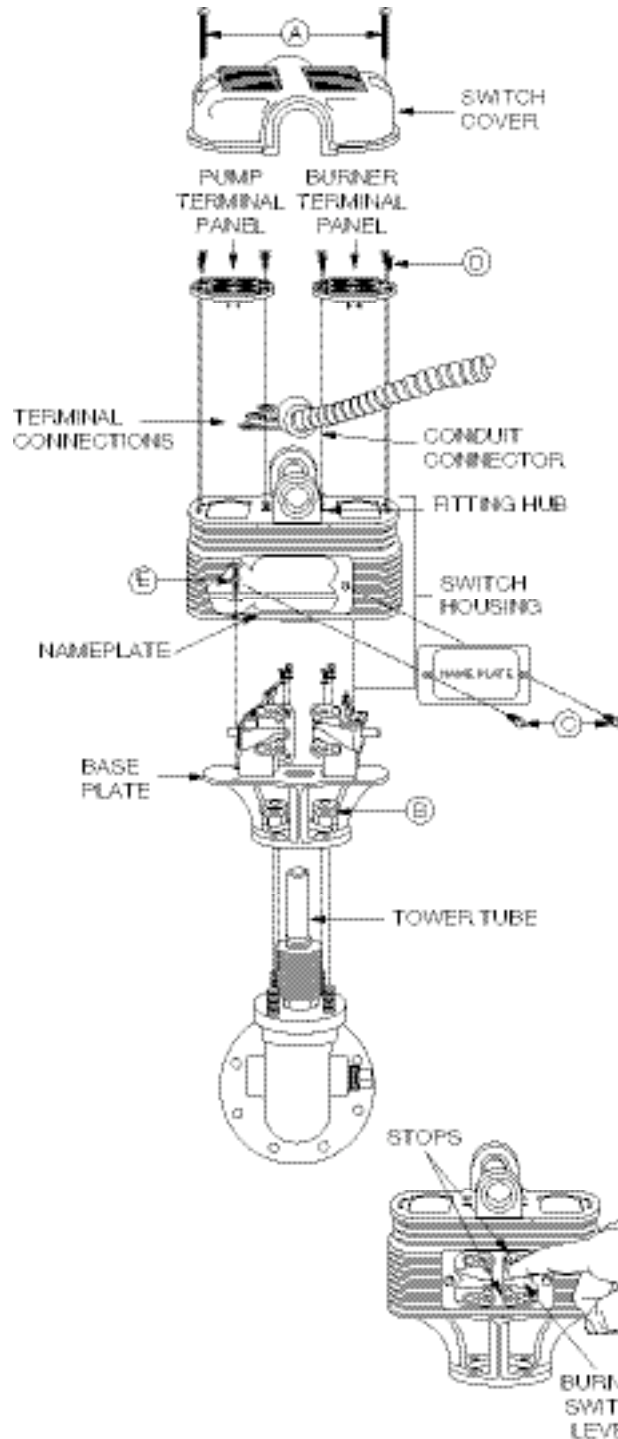

### c. Remove and Replace Switch Arm Contacts

- Remove two screws (F) and lift off bus bar (G), contact arms (H) and insulator (I).
- Place new insulator (I), contact arms (H) and bus bar (G) in position and fasten with two screws (F). Make sure the contact arm blades (H) are in alignment and at right angle to insulator.

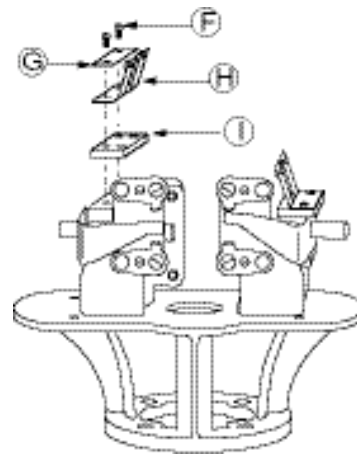

### d. Replace Switch Housing, Switch Assembly and Reconnect Wiring

- Replace **switch housing** and fasten to **base plate** with four screws (E).
- Move burner switch arms to upright position by reaching through **nameplate** opening and holding **burner switch lever** midway between **stops**. Carefully set **burner terminal panel** in position and fasten with screws (D). **Do not force**. (See diagram at lower right for proper orientation of terminal panel).
- Move pump switch arms to upright position by reaching through **nameplate** opening and holding **pump switch lever** midway between **stops**. Carefully set **pump terminal panel** in position and fasten with screws (D). **Do not force**. (See diagram at lower right for proper orientation of terminal panel).
- Check visually to see that **contact arms** are in proper position between terminal panel contacts and move lever up and down to see that switch operates freely and smoothly.
- Carefully slide **switch assembly** over **tower tube** and secure with four hex nuts (B).
- Install **conduit connector** and wires to the integral **fitting hub** on **switch assembly**.
- Reconnect wiring to **terminal panel** in exactly the same position as removed.
- Replace **switch cover** and fasten with two screws (A).
- Replace **nameplate** and fasten with two screws (C).

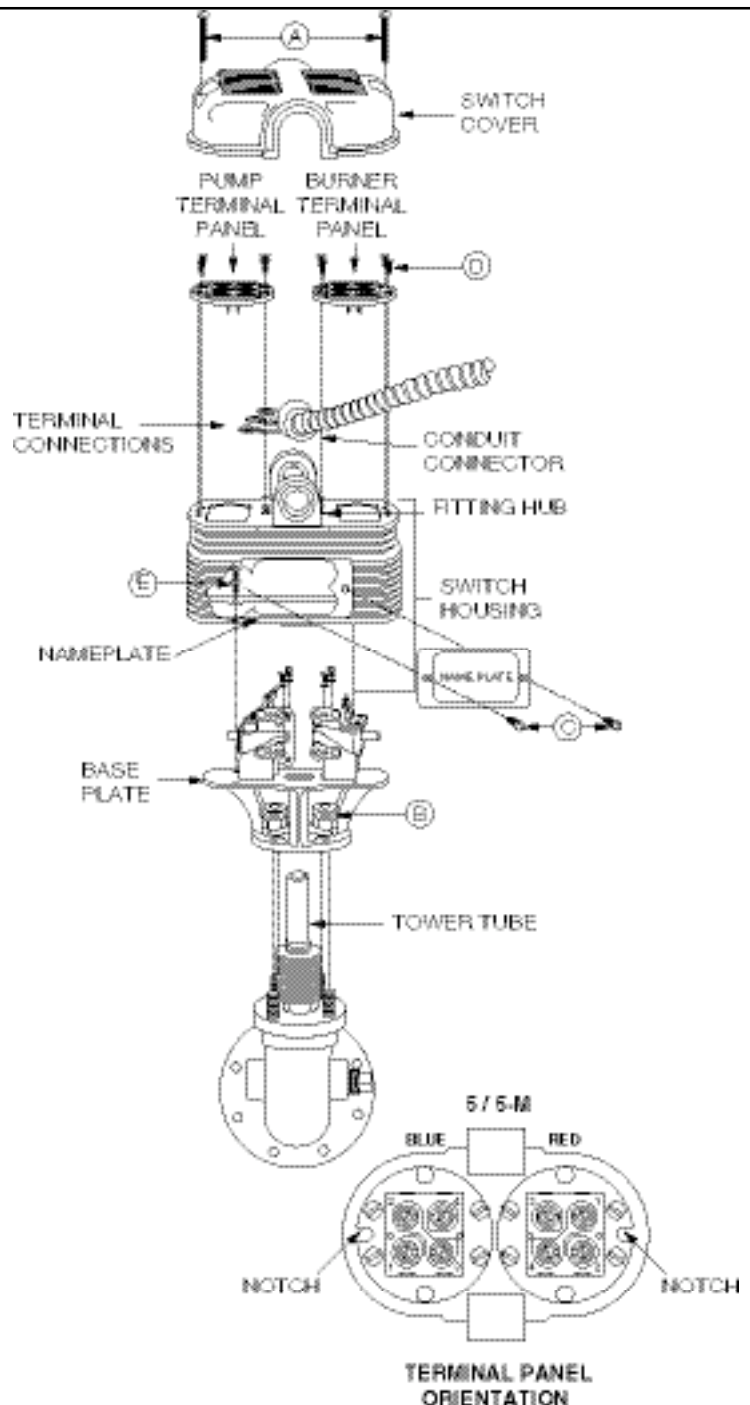

Proceed to Step 2 to Test Control



# ITT

# McDonnell & Miller

## STEP 2 - Testing

- Dimensions shown are typical.
- The following testing procedure is only meant to serve as a verification of proper operating sequence.

### a. Turn on power to boiler and pump circuits.

With the boiler empty, the pump should turn on (5 or 5-M switch models) or the valve open (7B or 7B-M switch models). The burner should remain off and boiler should begin to fill with water.

#### CAUTION

Immediately turn off all power if the burner turns on with no water in the gauge glass. Investigate further before continuing procedure.

### b. For Automatic Reset Models

When water level in the gauge glass is approximately 1 3/8" (35mm) above the horizontal cast line, the burner should turn on.

#### For Manual Reset Models

When water level in the gauge glass is approximately 1 3/8" (35mm) above the horizontal cast line, press the manual reset button and the burner should turn on.

### c. For 5 or 5-M Switch Models

When water level in the gauge glass is approximately 2 1/8" (54mm) above the horizontal cast line, the pump should turn off.

#### For 7B or 7B-M Switch Models

When water level in the gauge glass is approximately 2 11/16" (68mm) above the horizontal cast line, the valve should be closed.

#### CAUTION

If pump does not turn off or valve close, turn off water supply to boiler. Investigate further before continuing procedure.

### d. With the water in the boiler at its normal level and burner on, SLOWLY open the blow-down valve until it is fully open. As the water level in the gauge glass begins to drop, verify that the following occurs.

#### For 5 or 5-M Switch Models

When water level drops to approximately 1 1/8" (29mm) above the horizontal cast line, the pump should turn on.

When water level drops to the horizontal cast line, the burner should turn off.

#### For 7B or 7B-M Switch Models

As the water level drops, the valve should begin to open.

When the water level drops to approximately 7/8" (22mm) above the horizontal cast line, the valve should be full open.

When the water level drops to the horizontal cast line, the burner should turn off.

### e. Close the blow-down valve after burner turns off and restore water level to normal operating level.

### f. Repeat testing procedure several times to ensure proper operation of control.

### g. After testing and verification of control operation, the boiler can be returned to service.