

JOB:	REPRESENTATIVE:	
UNIT TAG:	ORDER NO.	DATE:
ENGINEER:	SUBMITTED BY:	DATE:
CONTRACTOR:	APPROVED BY:	DATE:

SHOWN WITH
OPTIONAL PANEL

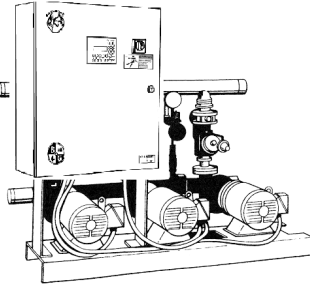

3 Pump 70E Series Pressure Booster System

DESIGN DATA:

Maximum System Capacity Required:		GPM
Pressure Required at Discharge Header:		PSIG
Minimum Suction Pressure to Suction Header:		PSIG
Pressure Drop through Package and PRV's:		PSIG
Required Boost Developed by 70E		PSIG
Header Size		IN.

PUMP DATA:

	Pump No. 1	Pump No. 2	Pump No. 3
Gallons per Minute			
TDH*			
PRV			
Series <u>1531</u>	Size <u> </u>		
Motor HP			
Motor RPM <u> </u>	Voltage <u> </u>	Hertz <u> </u>	Phase <u> </u>

*Note: TDH includes PRV and package losses.

**STANDARD
EQUIPMENT:**

The packaged pumping system shall be constructed with Type L copper headers. Unit shall be rated for 150 PSIG working pressure. Headers shall be easily removable to allow for service access and moving the package through doorways. Pump shall be centrifugal, close-coupled, single stage, end suction type. Pumps shall be rated for a minimum 175 PSIG working pressure. Casings shall have gauge ports and vent and drain ports at top and bottom of casing. Motors shall meet NEMA specifications and shall be of the size, voltage, and enclosure called for on the plans. A globe style, in-line combination pressure reducing and check valve shall be installed on the discharge of each pump. The valve shall have an epoxy coated body with a bronze disc. The valve pilot shall be a direct acting, adjustable, spring-loaded, normally open diaphragm valve. Isolation valves shall be provided for each pump and PRV set. Pressure transducers shall be installed on the suction and discharge headers. Pumps shall be protected from thermal accumulation via a common thermal relief mechanism.

70E DIMENSIONAL DATA

DIMENSIONS - Inches

MODEL NO. 1750 RPM	MODEL NO. 3500 RPM	1531 PUMPS		PRV		A (MAX)	B (MAX)
		LEAD	LAG	LEAD	LAG		
31A	3AA	1 1/4 AC	1 1/4 AC	1.5	1.5	70.50	49.25
39A	3PA	1 1/4 AC	1 1/2 AC	1.5	1.5	73.25	54.00
39E	3PE	1 1/4 AC	1 1/2 AC	1.5	2	73.25	54.00
3JE	3QE	1 1/4 AC	2AC	1.5	2	73.38	48.50
3JF	3QF	1 1/4 AC	2AC	1.5	2.5	73.38	48.50
3KF	3RF	1 1/4 AC	2 1/2 AB	1.5	2.5	73.38	48.50
3KG	3RG	1 1/4 AC	2 1/2 AB	1.5	3	73.38	48.50
32A	3BA	1 1/2 AC	1 1/2 AC	1.5	1.5	70.50	49.25
32E	3BE	1 1/2 AC	1 1/2 AC	1.5	2	73.25	54.00
32B	3BB	1 1/2 AC	1 1/2 AC	2	2	70.50	49.25
33B	3CB	2AC	2AC	2	2	70.50	47.38
33H	3CH	2AC	2AC	2	2.5	73.88	46.63
33C	3CC	2AC	2AC	2.5	2.5	70.50	47.38
34C	3DC	2 1/2 AB	2 1/2 AB	2.5	2.5	70.50	47.38
34J	3DJ	2 1/2 AB	2 1/2 AB	2.5	3	73.38	48.38
34D	3DD	2 1/2 AB	2 1/2 AB	3	3	70.50	47.38
35A	3EA	1 1/4 BC	1 1/4 BC	1.5	1.5	70.50	49.25
3LA	3SA	1 1/4 BC	1 1/2 BC	1.5	1.5	74.38	56.63
3LE	3SE	1 1/4 BC	1 1/2 BC	1.5	2	74.38	56.63
3ME	3TE	1 1/4 BC	2BC	1.5	2	74.50	54.75
3MF	3TF	1 1/4 BC	2BC	1.5	2.5	74.50	54.75
3NF	3UF	1 1/4 BC	2 1/2 BB	1.5	2.5	74.50	54.75
3NG	3UG	1 1/4 BC	2 1/2 BB	1.5	3	74.50	54.75
36A	3FA	1 1/2 BC	1 1/2 BC	1.5	1.5	70.50	49.25
36E	3FE	1 1/2 BC	1 1/2 BC	1.5	2	74.38	56.63
36B	3FB	1 1/2 BC	1 1/2 BC	2	2	70.50	49.25
37B	3GB	2BC	2BC	2	2	70.50	47.38
37H	3GH	2BC	2BC	2	2.5	74.50	49.88
37C	3GC	2BC	2BC	2.5	2.5	70.50	47.38
38C	3HC	2 1/2 BB	2 1/2 BB	2.5	2.5	70.50	47.38
38J	3HJ	2 1/2 BB	2 1/2 BB	2.5	3	74.50	49.88
38D	3HD	2 1/2 BB	2 1/2 BB	3	3	70.50	47.38

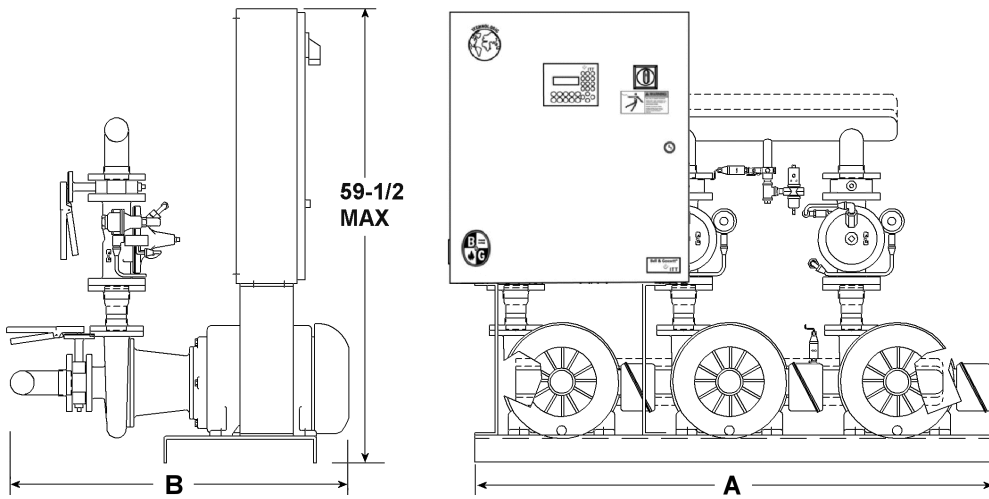

Panel Included
 Yes
 No

END CAP LOCATION
 (Based on facing front panel)
 Both right, as shown
 Both left
 Suction Left, Discharge right
 Suction right, discharge left

Do not use for construction. Dimensions are approximate and subject to change. Contact factory for certified dimensions

